

# Temperature difference controller STDC



**Installation and operating instructions  
applies to STDC version 1 - 4**



**Read carefully before installation, commissioning and operation**

# CONTENT

<b>Safety Instructions</b> .....	<b>4</b>	Speed control .....	20
EU-Conformity .....	4	Variant .....	20
General Instructions .....	4	Purging time .....	20
Explanation of Symbols .....	4	Sweep time .....	20
Changes to the Unit .....	5	Max. Speed .....	20
Warranty and Liability .....	5	Min. Speed .....	21
Disposal and Pollutants .....	5	Setpoint .....	21
<b>Description STDC</b> .....	<b>5</b>	Time & Date .....	21
About the Controller .....	5	Sensor Calibration .....	21
Technical Data .....	6	Commissioning .....	21
Scope of Supply .....	6	Factory settings .....	21
Hydraulic Variants .....	7	Heat quantity .....	21
<b>Installation</b> .....	<b>8</b>	Starting aid .....	22
Electrical Terminals .....	8	Purging time .....	22
Electrical Terminals .....	9	Increase .....	22
wall Installation .....	11	Daylight saving time .....	22
Electrical Connection .....	12	<b>8. Menu Lock</b> .....	<b>22</b>
Installing the Temperature Sensors .....	13	<b>9. Service Values</b> .....	<b>22</b>
Temperature Resistance Table for Pt1000 Sensors .....	13	<b>10. Language</b> .....	<b>23</b>
<b>Operation</b> .....	<b>13</b>	<b>Malfunctions/Maintenance</b> .....	<b>23</b>
Display and Input .....	13	Final Declaration .....	24
Commissioning help .....	14		
<b>1. Measurement values</b> .....	<b>14</b>		
<b>2. Statistics</b> .....	<b>15</b>		
Operating hours .....	15		
Average $\Delta T$ .....	15		
Heat quantity .....	15		
Graphic overview .....	15		
Message Log .....	15		
Reset / Clear .....	15		
<b>3. Display mode</b> .....	<b>15</b>		
Schematic .....	15		
Overview .....	16		
Alternating .....	16		
Eco Display Mode .....	16		
<b>4. Operating Mode</b> .....	<b>16</b>		
Auto .....	16		
Manual .....	16		
Aus .....	16		
<b>5. Settings</b> .....	<b>16</b>		
Tmin S1 .....	17		
Tmin S2 .....	17		
$\Delta T$ R1 .....	17		
Tset On .....	17		
Tmax S1 .....	17		
Thermostat periods .....	17		
Tmin Storage X .....	17		
<b>6. Protective Functions</b> .....	<b>18</b>		
Seizing Protection .....	18		
Frost Protection .....	18		
System protection .....	18		
Collector protection .....	18		
Collector alarm .....	18		
Recooling .....	19		
Anti-Legionella .....	19		
<b>7. Special Functions</b> .....	<b>19</b>		
Program selection .....	19		
Signal .....	19		
Signal type .....	20		
Output Signal .....	20		
PWM / 0-10V off .....	20		
PWM / 0-10V on .....	20		
PWM / 0-10V max. .....	20		
Show signal .....	20		

This manual applies to the following different hardware versions.

**STDC Version 1**

3 temperature sensor inputs  
1 relay output 230 AC (on/off)

**STDC Version 2**

3 temperature sensor inputs  
1 electronic relay output 230 AC (for speed control of standard pumps)

**STDC Version 3**

3 temperature sensor inputs  
1 relay output 230 AC (on/off)  
1 PWM/0-10V output (for speed control of high efficiency pumps)

**STDC Version 4**

3 temperature sensor inputs  
1 electronic relay output 230 AC (for speed control of standard pumps)  
1 PWM/0-10V output (for speed control of high efficiency pumps)

**If the version is not visible there, please go to the menu "Service values" in the controller. In the first line you can read the version.**

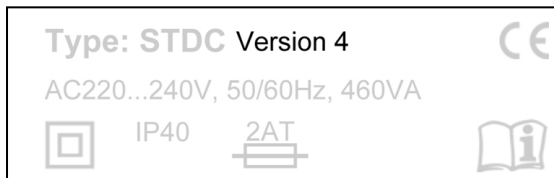

## EU-Conformity

By affixing the CE mark to the unit the manufacturer declares that the STDC conforms to the following relevant safety regulations:

- EU low voltage directive 2014/35/EU
- EU electromagnetic compatibility directive 2014/30/EU

conforms. Conformity has been verified and the corresponding documentation and the EU declaration of conformity are kept on file by the manufacturer.

## General Instructions

### Please read carefully!

These installation and operating instructions contain basic instructions and important information regarding safety, installation, commissioning, maintenance and the optimal use of the unit. Therefore these instructions must be read and understood completely by the installation technician/specialist and by the system user before installation, commissioning and operation of the unit.

This unit is an automatic, electrical Temperature difference controller for/solar or heating system and similar applications. Install the unit only in dry areas and under the ambient conditions described in "Specifications".

The valid accident prevention regulations, VDE regulations, the regulations of the local power utility, the applicable DIN-EN standards and the installation and operating instruction of the additional system components must also be observed.

Under no circumstances does the unit replace any safety devices to be provided by the customer!

Installation, electrical connection, commissioning and maintenance of the device may only be carried out by an appropriately trained specialist. Users: Make sure that the specialist gives you detailed information on the function and operation of the unit. Always keep these instructions in the vicinity of the unit.

The manufacturer does not take over any liability for damage caused through improper usage or non-compliance of this manual!

## Explanation of Symbols



Danger

Failure to observe these instructions can result in electrocution.



Danger

Failure to observe these instructions can result in serious damage to health such as scalding or life-threatening injuries.



Caution

Failure to observe these instructions can result in destruction of the unit or the system, or environmental damage.



Caution

Information which is especially important for the function and optimal use of the unit and the system.

## Changes to the Unit

---

- Changes, additions to or conversion of the unit are not permitted without written permission from the manufacturer.
- It is likewise forbidden to install additional components that have not been tested together with the unit.
- If it becomes clear that safe operation of the unit is no longer possible, for example because of damage to the housing, turn the Unit off immediately.
- Any parts of the unit or accessories that are not in perfect condition must be exchanged immediately.
- Use only original spare parts and accessories from the manufacturer.
- Markings made on the unit at the factory must not be altered, removed or made illegible.
- Only the settings described in these instructions may be set using the Unit.



Changes to the unit can compromise the safety and function of the unit or the entire system.

## Warranty and Liability

---

The unit has been manufactured and tested with regard to high quality and safety requirements. The unit is subject to the statutory guarantee period of two years from the date of sale. The warranty and liability shall not include, however, any injury to persons or material damage that is attributable to one or more of the following causes:

- Failure to observe these installation and operating instructions.
- Improper installation, commissioning, maintenance and operation.
- Improperly executed repairs.
- Unauthorised structural changes to the unit.
- Use of the device for other than its intended purpose.
- Operation above or below the limit values listed in the 'Specifications' section.
- Force majeure.

## Disposal and Pollutants

---

The unit conforms to the European RoHS 2011/65/EU for the restriction of the use of certain hazardous substances in electrical and electronic equipment.



Under no circumstances may the device be disposed of with the normal household waste. Dispose of the unit only at appropriate collection points or ship it back to the seller or manufacturer.

## Description STDC

## About the Controller

---

The Temperature difference controller STDC facilitates efficient use and function control of your solar or heating system possible while its handling is intuitive. After every input step the suitable functions are matched to the keys and explained in a text above. In the menu 'measurement values and settings' are help text and graphics in addition to key words.

The STDC can be used for the various system variants. "Hydraulic Variants" on page 7

Important characteristics of the STDC are:

- Depiction of graphics and texts using a lit display.
- Simple viewing of the current measurement values.
- Statistics and system monitoring by means of statistical graphics
- Extensive setting menus with explanations.
- Menu block can be activated to prevent unintentional setting changes.
- Resetting to previously selected values or factory settings.

## Technical Data

---

### Electrical specifications:

Power Supply		230VAC +/- 10%, 50 - 60 Hz
Power consumption / standby		1,5W - 2W/ 0,5 W
Internal fuse	1	1
Protection Class		IP40
Protection Class		II
Overvoltage category		II
Degree of pollution category		II

---

### Inputs/Outputs

	Version 1	Version 2	Version 3	Version 4
Pt1000 Measuring range -40 °C ... 300 °C	3	3	3	3
mechanical relay as alternating contact ( $\bar{R}$ ) 460VA for AC1 / 460W for AC3	1	-	1	-
electronic relay min. 5W ... max. 120W for AC3	-	1	-	1
0-10V output (Tolerance +/- 10%) 10 k $\Omega$ load	-	-	V1	V1
PWM output freq. 1 kHz, level 10 V	-	-	V1	V1

---

### Max. Cable Length

Collector sensor	S1	< 30 m
Storage sensor	S2 and S3	< 10 m
0-10V/PWM		< 3 m
mechanical relay		< 10 m
electronic relay		<3m

---

### Permissible Ambient Conditions

for controller operation	0 °C - 40 °C, max. 85 % rel. humidity at 25 °C
for transport/storage	0 °C - 60 °C, no moisture condensation permitted

---

### Other Specifications and Dimensions

Housing Design	2-part, ABS plastic
Installation Methods	Wall installation, optionally panel installation
Overall dimensions	115 mm x 86 mm x 45 mm
Aperture installation dimensions	108 mm x 82 mm x 25,2 mm
Display	Fully graphical display, 128 x 64 dots
Real Time Clock	RTC with 24 hour power reserve
Operation	4 entry keys

---

## Scope of Supply

---

- Single circuit solar controller STDC
- 4 strain relief clips with 8 screws, replacement fuse 2AT
- 2 screws 3,5 x 35 mm and 2 plugs 6 mm for wall installation.
- STDC installation and operating instructions

# Hydraulic Variants



The following illustrations should be regarded only as schematic representations of the respective hydraulic systems and do not claim to be complete. Under no circumstances should the controller replace any safety devices. Depending on the specific application, additional system and safety components such as check valves, non-return valves, safety temperature limiters, scalding protectors, etc., may be required.



For 3-way valves, the flow direction in energized state (relay active) is shown in the used hydraulic version.

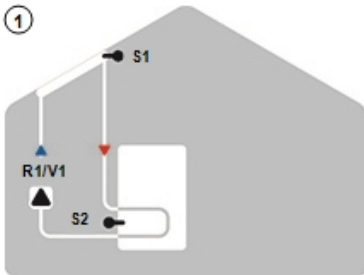

Solar with reservoir

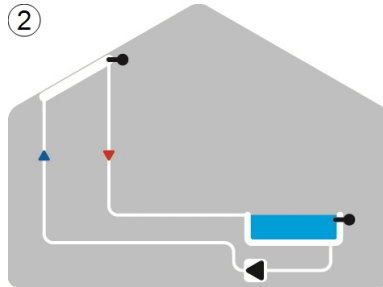

Solar with pool

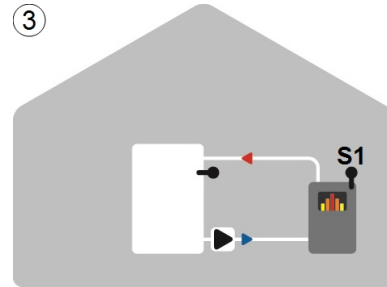

Solid fuel boiler with storage

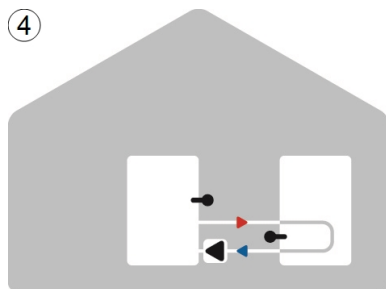

Storage transfer

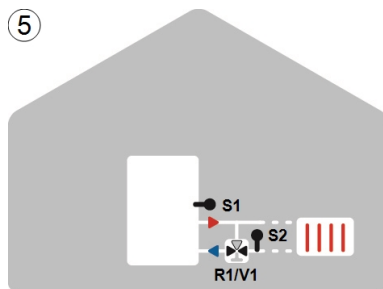

Heating circuit return flow increase

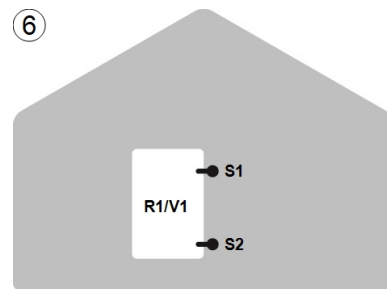

Thermostat

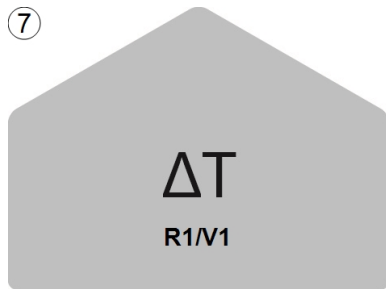

Universal Delta T

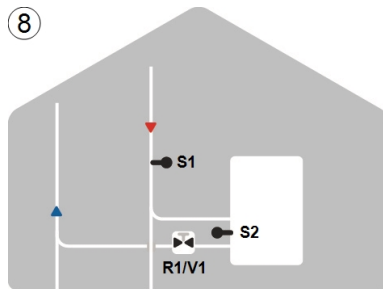

Shutoff valve

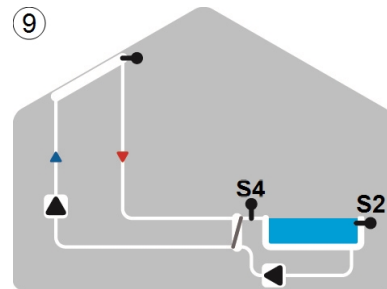

Solar with pool and heat exchanger 1

## Electrical Terminals



**Mains voltages**  
230 VAC 50 - 60 Hz



**Low voltages**  
max. 12 VAC / DC

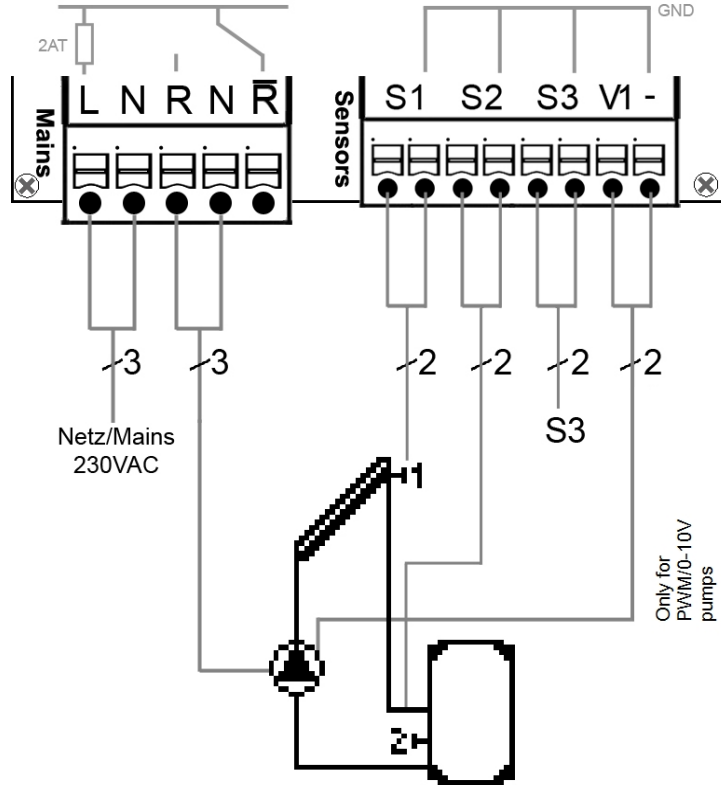

Terminal:	Connection for:
L	Network outer conductor L
N	Network neutral conductor N
R	Relay 3 closer
N	Neutral conductor N Relay
R	Relay opener

Terminal:	Connection for:
S1	Temperature Sensor 1
S2	Temperature Sensor 2
S3	Temperature Sensor 3
V1	0-10V / PWM output for speed controlled HE-pumps
-	GND V1

The PE protective conductor must be connected to the PE metal terminal block!



**"Connection of PWM pumps"**

PWM pumps are connected to the controller with 2 wires **1)** PWM Input (default: brown) **2)** GND (default: blue). Some pumps have a third wire (PWM Output Signal (default: black)). This is not used for the connection!



The matching terminal assignment to your system or hydraulic diagram, see the descriptions in the respective hydraulic diagram, "Hydraulic Variants" on page 7.

# Electrical Terminals

**!** For high-efficiency pumps with 0-10V / PWM signal input, the power can be provided (V1 parallel operation) over a free relay.

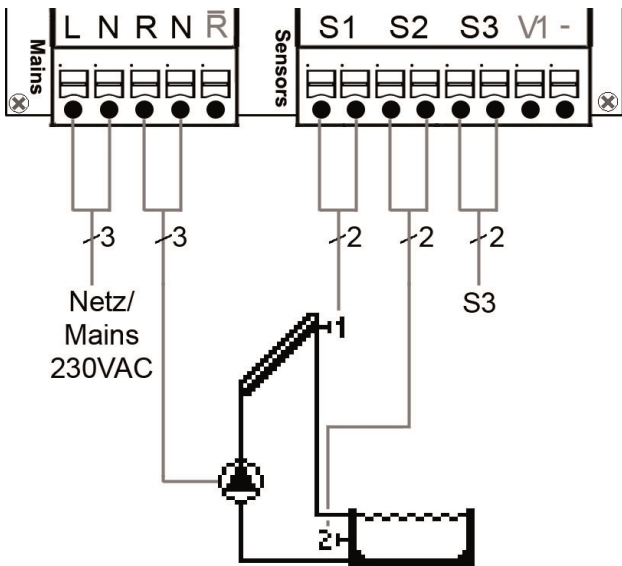

Program 2 Solar with pool



**Mains voltages**  
230VAC 50-60Hz



**Low Voltage**  
max. 12VAC/DC

Terminal:	Connection:	Terminal:	Connection:
L	Network outer conductor L	S1 (2x)	Sensor 1 collector
N	Network neutral conductor N	S2 (2x)	Sensor 2 Pool
R	Pump outer conductor L	S3 (2x)	Sensor 3 (optional)
N	Pump neutral conductor N	The polarity of the sensors S1-S3 is freely selectable.	
R	Break contact (STDC Version 1+3)	V1	0-10V/ PWM +/- ( STDC Version 3+4 )
		-	GND V1

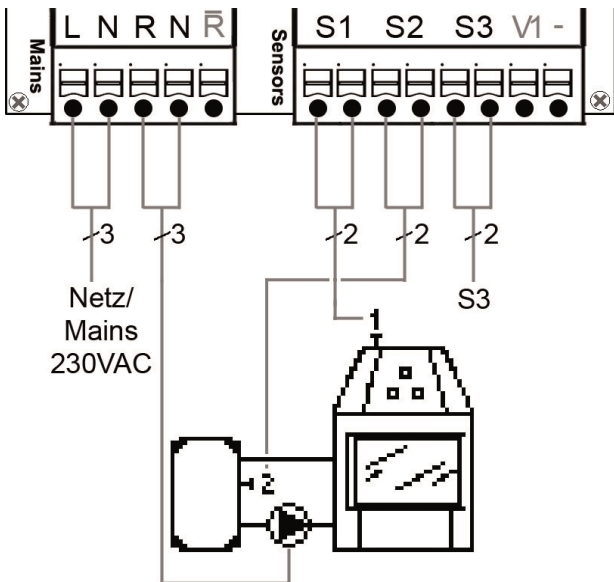

Program 3 Solid fuel with storage tank



**Mains voltages**  
230VAC 50-60Hz



**Low Voltage**  
max. 12VAC/DC

Terminal:	Connection:	Terminal:	Connection:
L	Network outer conductor L	S1 (2x)	Sensor 1 solid fuel boiler
N	Network neutral conductor N	S2 (2x)	Sensor 2 storage
R	Pump outer conductor L	S3 (2x)	Sensor 3 (optional)
N	Pump neutral conductor N	The polarity of the sensors S1-S3 is freely selectable.	
R	Break contact (STDC Version 1+3)	V1	0-10V/ PWM +/- ( STDC Version 3+4 )
		-	GND V1

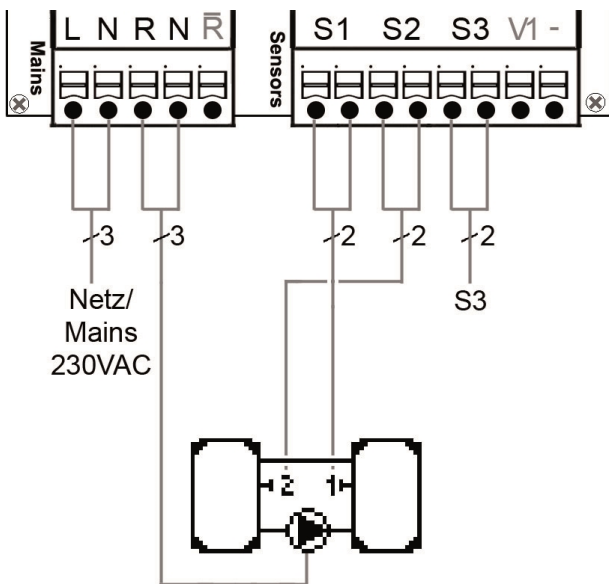

Program 4 Storage transfer



**Mains voltages**  
230VAC 50-60Hz



**Low Voltage**  
max. 12VAC/DC

Terminal:	Connection:	Terminal:	Connection:
L	Network outer conductor L	S1 (2x)	Sensor 1 storage 1
N	Network neutral conductor N	S2 (2x)	Senaor 2 storage 2
R	Pump outer conductor L	S3 (2x)	Sensor 3 (optional)
N	Pump neutral conductor N	The polarity of the sensors S1-S3 is freely selectable. N	
R	Break contact (STDC Version 1+3)	V1	0-10V/ PWM +/- ( STDC Version 3+4 )
		-	GND V1

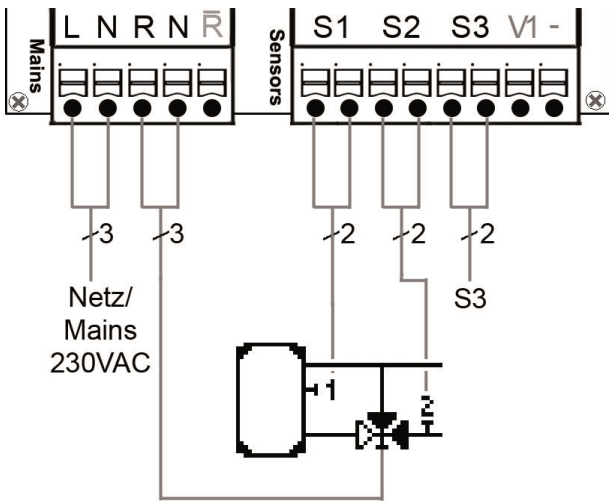

**Program 5 Raising of heat circuit**



**Mains voltages**  
230VAC 50-60Hz



**Low Voltage**  
max. 12VAC/DC

Terminal:	Connection:	Terminal:	Connection:
L	Network outer conductor L	S1 (2x)	Sensor 1 storage 1
N	Network neutral conductor N	S2 (2x)	Sensor 2 Return flow
R	Valve outer conductor L	S3 (2x)	Sensor 3 (optional)
N	Valve neutral conductor N	The polarity of the sensors S1-S3 is freely selectable. N	
R	Break contact (STDC Version 1+3)	V1	0-10V/ PWM +/- ( STDC Version 3+4 )
		-	GND V1

**Actuating direction of valve:**

R1 on/valve on = direction through the storage tank

**Program 6 thermostat**

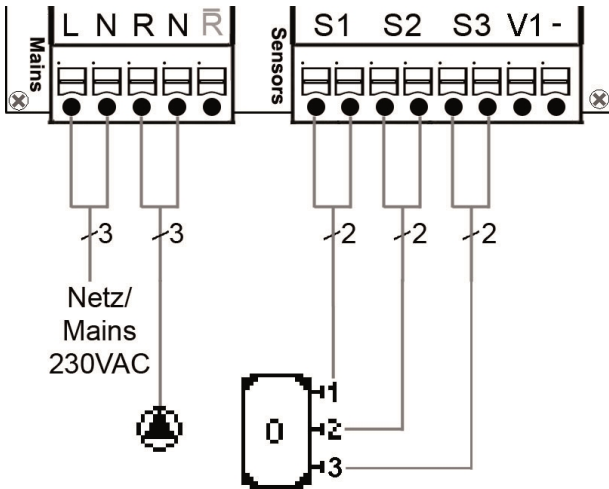

**Mains voltages**  
230VAC 50-60Hz



**Low Voltage**  
max. 12VAC/DC

Terminal:	Connection:	Terminal:	Connection:
L	Network outer conductor L	S1 (2x)	Sensor 1 storage top
N	Network neutral conductor N	S2 (2x)	Sensor 2 (optional)
R	Pump outer conductor L	S3 (2x)	Sensor 3 (optional)
N	Pump neutral conductor N	The polarity of the sensors S1-S3 is freely selectable.	
R	Break contact (STDC Version 1+3)	V1	0-10V/ PWM +/- ( STDC Version 3+4 )
		-	GND V1

**Program 7 Universal ΔT controller**

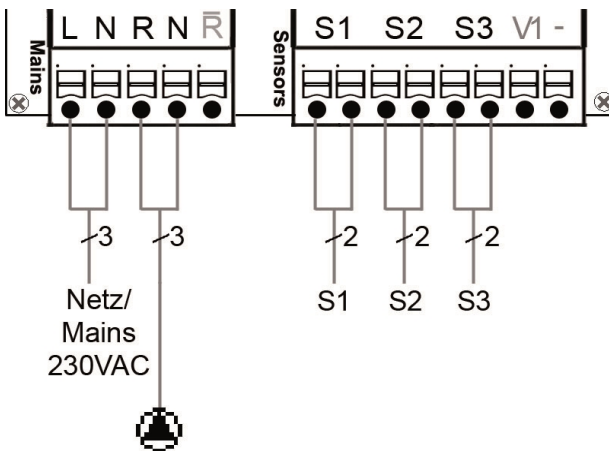

**Mains voltages**  
230VAC 50-60Hz



**Low Voltage**  
max. 12VAC/DC

Terminal:	Connection:	Terminal:	Connection:
L	Network outer conductor L	S1 (2x)	Sensor 1 control
N	Network neutral conductor N	S2 (2x)	Probe 2 reference
R	Pump outer conductor L	S3 (2x)	Sensor 3 (optional)
N	Pump neutral conductor N	The polarity of the sensors S1-S3 is freely selectable.	
R	Break contact (STDC Version 1+3)	V1	0-10V/ PWM +/- ( STDC Version 3+4 )
		-	GND V1

**Program 8 Shutoff valve**

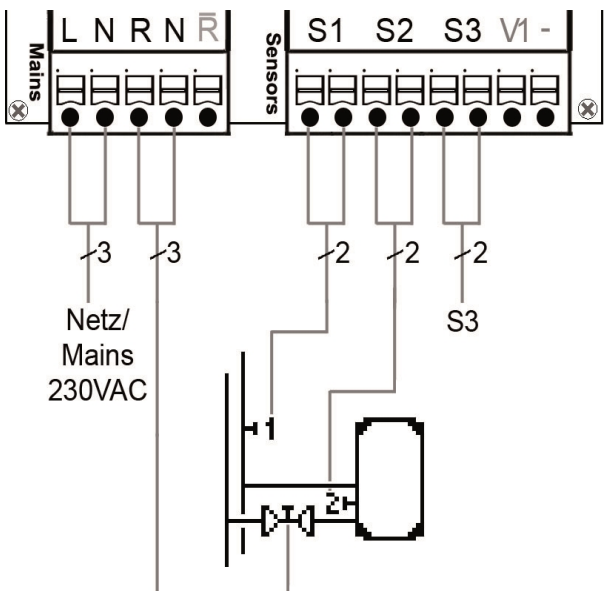

**Mains voltages**  
230VAC 50-60Hz



**Low Voltage**  
max. 12VAC/DC

Terminal:	Connection:	Terminal:	Connection:
L	Network outer conductor L	S1 (2x)	Sensor 1 flow
N	Network neutral conductor N	S2 (2x)	Sensor 2 storage
R	Shutoff valve outer conductor L	S3 (2x)	Sensor 3 (optional)
N	Stop valve neutral conductor N	The polarity of the sensors S1-S3 is freely selectable.	
R	Break contact (STDC Version 1+3)	V1	0-10V/ PWM +/- ( STDC Version 3+4 )
		-	GND V1

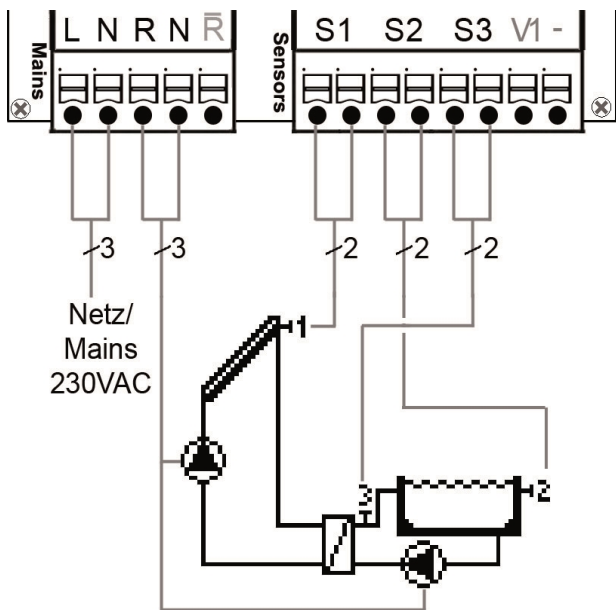

### Program 9 Solar with heat exchanger and pool



**Mains voltages**  
230VAC 50-60Hz



**Low Voltage**  
max. 12VAC/DC

Terminal:	Connection:	Terminal:	Connection:
L	Network outer conductor L	S1 (2x)	Sensor 1 collector
N	Network neutral conductor N	S2 (2x)	Sensor 2 pool
R	Pump outer conductor L	S3 (2x)	Sensor 3 secondary circuit
N	Pump neutral conductor N	The polarity of the sensors S1-S3 is freely selectable.	
R	Break contact (STDC Version 1+3)	V1	0-10V/ PWM +/- ( STDC Version 3+4 )
		-	GND V1

Both pumps are connected to the same relay.

## wall Installation

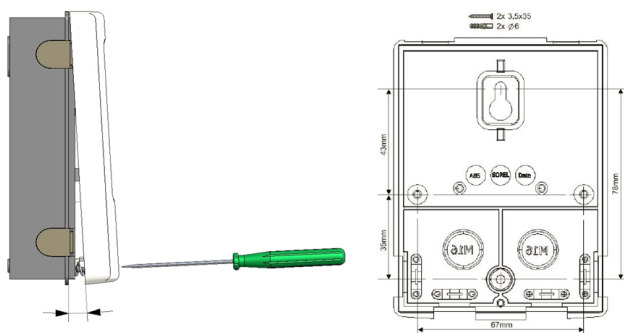

1. Unscrew cover screw completely.
2. Carefully pull upper part of housing from lower part.
3. Set upper part of housing aside. Do not touch the electronics.
4. Hold the lower part of the housing up to the selected position and mark the two mounting holes. Make sure that the wall surface is as even as possible so that the housing does not become distorted when screwed on.
5. Using a drill and size 6 bit, drill three holes at the points marked on the wall and push in the plugs. Optionally the housing can be mount with 4 mounting holes.
6. Insert the upper screw and screw it in lightly.
7. Fit the upper part of the housing and insert the other two screws.
8. Align the housing and tighten the three screws.

If problems occur with the operation of the terminals, our video on our YouTube page can help you:





<http://www.sorel.de/youtube>

# Electrical Connection

 Before working on the unit, switch off the power supply and secure it against being switched on again! Check that there is no power flowing! Electrical connections may only be made by a specialist and in compliance with the applicable regulations. The unit may not be put into operation if there is visible damage to the housing, e.g. cracks.

 The unit may not be accessible from behind.

 Low-voltage cables such as temperature sensor cables must be routed separately from mains voltage cables. Feed temperature sensor cables only into the left-hand side of the unit, and mains voltage cables only into the right-hand side.

 The customer must provide an all-pole disconnecting device, e.g. an emergency heating switch.

 The cables being connected to the unit must not be stripped by more than 55 mm, and the cable jacket must reach into the housing just to the other side of the strain relief.

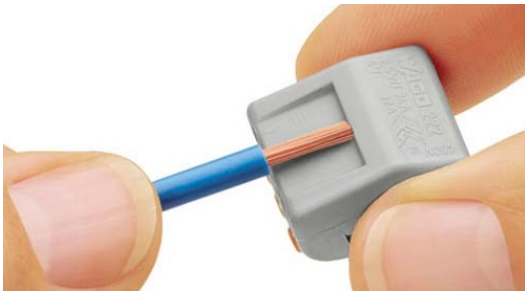

Fig. 1



Fig. 2

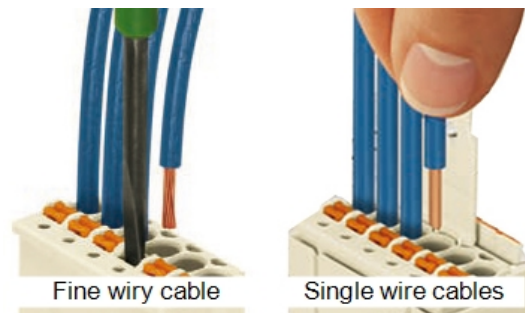

Fig. 3 | Fig. 3.1

1. Select required program/ hydraulic variants.
2. Strip cables by 55 mm max., (fig.1) strip the last 9-10 mm of the wires.
3. Open controller housing (" wall Installation " on page 11).
4. Install PE terminal block (Fig.2)
5. Connect the supplied connection terminals " Electrical Terminals " on page 8.  
When using fine-stranded cables with a screwdriver, press the orange handles. (Fig. 3)  
For single-wire cables or cables equipped with wire-end ferrules, simply insert the cable. (Fig. 3.1.).
6. Insert the connecting terminals into the appropriate pin strips.
7. Mount strain reliefs.
8. Hang on the upper housing part and close the housing with gentle pressure
9. Cover screw tighten.
10. Turn on mains supply and operate the controller.

# Installing the Temperature Sensors

The controller operates with Pt1000 temperature sensors which are accurate to 1 °C, ensuring optimal control of system functions.

**!** If desired, the sensor cables can be extended to a maximum of 30 m using a cable with a cross-section of at least 0.75 mm<sup>2</sup>. Ensure there is no contact resistance! Position the sensor precisely in the area to be measured! Only use immersion, pipe-mounted or flat-mounted sensors suitable for the specific area of application with the appropriate permissible temperature range.

**!** Low-voltage cables such as temperature sensor cables must be routed separately from mains voltage cables. Feed temperature sensor cables only into the left-hand side of the unit, and mains voltage cables only into the right-hand side.







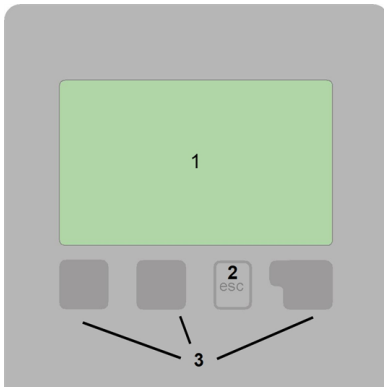

## Temperature Resistance Table for Pt1000 Sensors

°C	-20	-10	0	10	20	30	40	50	60	70	80	90	100
Ω	922	961	1000	1039	1077	1116	1155	1194	1232	1270	1308	1347	1385

## Operation

### Display and Input



-  Pump (rotates when active)
  -  Valve (direction of flow black)
  -  Collector
  -  Storage / buffer
  -  Solid fuel boiler
  -  Pool
  -  Thermostat On/Off
  -  Temperature Sensors
- Further symbols can be found in the special functions

Examples for key settings:

- +/- Increase / decrease values
- ▼/▲ Scroll menu down / up
- Yes/No agree / reject
- About further information
- Back to the previous display
- Ok Confirm selection
- Confirm Confirm setting

The display's (1), extensive text and graphical mode, enables simple, almost self-explanatory, operation of the controller.

The function of the other 3 keys (4) is shown in the display right above the keys. The right-hand key generally has a confirmation and selection function.

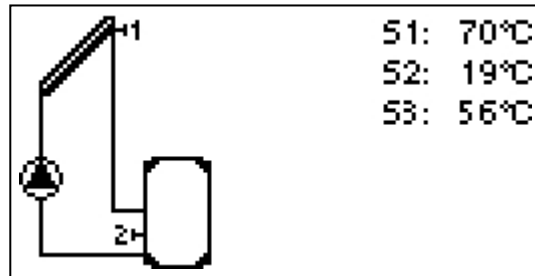

The graphics mode appears if not key is pressed for 2 minutes or after exiting the main menu with 'esc'.



Hitting the "esc" key in the graphics mode takes you directly to the main menu.

# Commissioning help



1. Set language and time
2. Commissioning help / setup wizard
  - a) select or
  - b) skip.

The setup wizard guides through the necessary basic settings in the correct order. Every parameter is explained on the display of the controller. Pressing the "esc" key takes you back to the previous setting.

b) With free commissioning the settings should be made in the following order:

- menu 10. Language
- menu 3. Time, Date and Operating Times.
- Menu 5. Settings, all values
- menu 6. Protection Functions (if any adjustments necessary).
- menu 7. Special Functions (if any adjustments necessary).

3. In menu operating mode "4.2. Manual" "4.1. Manual", test the witch outputs with the consumers connected and check the sensor values for plausibility. Then set to automatic mode. " Manual " on page 16



The setup wizard can be accessed in menu 7.6 at any time.



Consider the explanations for the individual parameters on the following pages and check if further settings are necessary for your application.

## 1. Measurement values

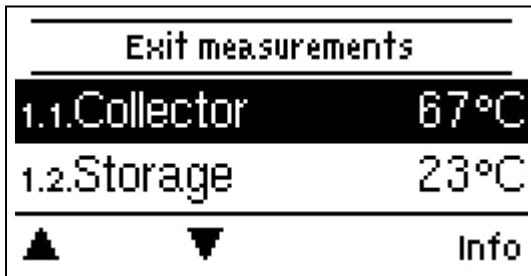

Serve to display the current measured temperatures.



If ,error' appears on the display instead of the measurement value, there may be a defective or incorrect temperature sensor.



If the cables are too long or the sensors are not well-placed, small deviations in the measurement values may occur. In this case, the display values can be compensated by adjustments in the controller " Sensor Calibration " on page 21. The selected program, connected sensors and the specific model design determine which measurement values are displayed.

## 2. Statistics

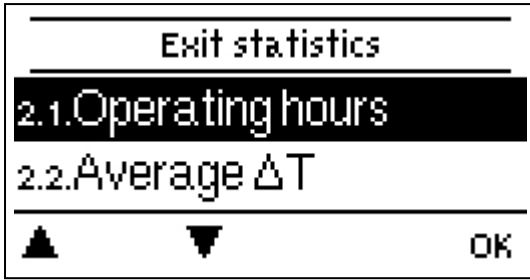

Serve for function control and long-term monitoring of the system.



For time-dependent functions such as circulation and anti-legionella and the evaluation of system data, it is essential that the time is accurately set on the controller. Please note that the clock continues to run for about 24 hours if the mains voltage is interrupted, and afterward must be reset. Improper operation or an incorrect time may result in data being cleared, recorded incorrectly or overwritten. The manufacturer accepts no liability for the recorded data!

### Operating hours

Display of the operating hours of the consumers connected to the controller (for example, solar pumps, valves etc.) whereby different time ranges (day-years) are available!

### Avarage ΔT

Display of the average temperature difference between the reference sensors when the switched on consumers.

### Heat quantity

Display of the consumed heat quantity form the system in kWh.



This is an indicative value.

### Graphic overview

This results in a clear illustration of the data as a bar graph. Different time ranges are available for comparison. You can page through with the two left keys.

### Message Log

Display of the last 20 errors in the system with indication of date and time.

### Reset / Clear

Resetting and clearing the selected statistics. Selecting ‚all statistics‘ clears everything except the messages.

## 3. Display mode

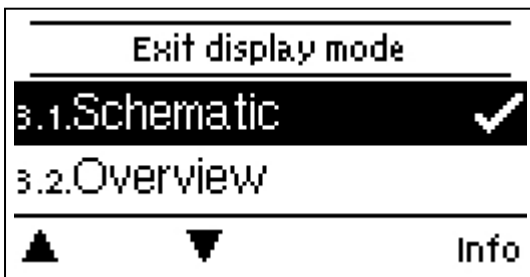

Used to define the controller's display for normal operation. This display appears whenever two minutes go by without any key being pressed. The main menu appears again when a key is pressed. The menu is closed by pressing "esc" or selecting "Exit display mode".

### Schematic

In the graphics mode, the selected hydraulic systems are displayed with the measured temperatures and operating states of the connected consumers.

## Overview

In the overview mode, the measured temperatures and operating states of the connected consumers are displayed in text form.

## Alternating

In alternating mode the schematic mode and then the overview mode are active for 5 seconds.

## Eco Display Mode

In Eco Display Mode the backlight of the display is switched off if no buttons are pushed for 2 minutes.

 If a message exists, the backlight does not switch off until the message has been scanned by the user.

## 4. Operating Mode

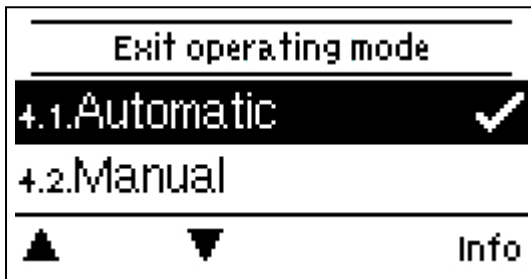

## Auto

The automatic mode is the normal mode of the controller. A correct controller function under consideration of the current temperatures and the set parameters is only present in automatic mode! After an interruption of the mains voltage, the controller automatically returns to the last operating mode selected.

## Manual

The individual relay outputs, v outputs and the connected consumers can be checked for proper functioning and correct assignment.

 The operating mode 'Manual' may only be used by specialists for brief function tests, e.g. during commissioning! Function in manual mode: The relays and thus the connected consumers are switched on and off by pressing a key, with no regard to the current temperatures and set parameters. At the same time, the current measurement values of temperature sensors are also shown in the display for the purposes of function control.

## Aus

 If the operating mode "off" is enabled, all control functions are turned off. The measured temperatures are displayed for the overview.

## 5. Settings

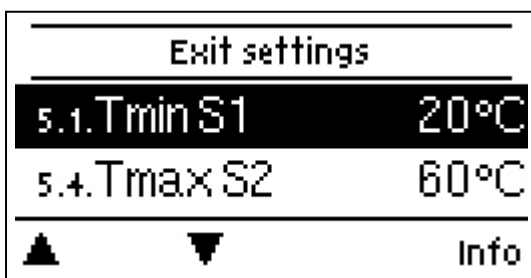

 By no means does the controller replace the safety appliances on site!

## Tmin S1

---

### Enable/start temperature at sensor 1:

If this value on the sensor 1 (collector sensor) is exceeded and the other conditions are not fulfilled, the controller will turn on the affiliated pump or the valve. If the temperature on the sensor 1 falls 5 °C below this value, the pump or the valve will be turned off again.

## Tmin S2

---

### Switch off temperature at sensor 2:

If this value is exceeded on the sensor 2, the controller turn off the affiliated pump or the valve. If this value on the sensor 2 is undershot and the other conditions are fulfilled, the controller will turn on the pump or the valve.

 Temperature values which are set too high can lead to scalding or damage to the system. Scalding protection must be provided by the customer!

In multiple storage systems, if the shut-down temperature S2 is exceeded, a downstream installed storage or storage area is switched to.

## ΔT R1

---

### On/off temperature difference for solar charge through relay R1:

If the temperature difference  $\Delta T$  Solar between the reference sensors S1 and S2 is exceeded and the other conditions are fulfilled, the controller will turn on the pump on the relay R1. If the temperature difference falls to  $\Delta T$  Off, the pump will be turned off.

 If the set temperature difference is too small, this may lead to ineffective operation depending on the system and sensor positioning. For speed regulation (" Speed control " on page 20), special switch conditions apply!

## Tset On

---

### Reference temperature sensor 1

Heating mode = 1. Value smaller than 2. value,

Cooling mod = 1. Value bigger than 2. value.

If the set switch-on value (1. Value) at sensor 1 undershot and thermostat function is approved (see also 5.5), backup heating is switched on until temperature exceeds value for switch off (2. Value).

 Temperature values which are set too high can lead to scalding or damage to the system. Scalding protection must be provided by the customer!

 If sensor S2 is connected, S1 functions as a switch-on sensor and S2 as a switch-off sensor.

## Tmax S1

---

### Switch off temperature at sensor 1

If this value is exceeded on the sensor 1, the controller turn off the affiliated pump or the valve. If sensor 1 falls below this value again and the other conditions are also met, then the controller switches the pump and/or valve on again.

 Temperature values which are set too high can lead to scalding or damage to the system. Scalding protection must be provided by the customer!

## Thermostat periods

---

Here the desired periods are set in which the thermostat function is approved. For each weekday, three times can be specified, furthermore, you can copy individual day to other days. The thermostat function is shut down outside of the set times.

## Tmin Storage X

---

### Switch off temperature at sensor S(X)

If this value is exceeded at sensor X then the controller switches the associated pump and/or valve off. If sensor (X) falls below this value again and the other conditions are also met, then the controller switches the pump and/or valve on again.



Temperature values which are set too high can lead to scalding or damage to the system. Scalding protection must be provided by the customer!

## 6. Protective Functions



The 'Protective functions' can be used by specialists to activate and set various protective functions.



By no means does the controller replace the safety appliances on site!

### Seizing Protection

If the anti-seizing protection is activated (daily, weekly, off), the controller switches the outputs on/off at 12:00 noon for 5 seconds to prevent seizing of the pump/valve after long periods of inactivity.

### Frost Protection

If the temperature at the outdoor sensor falls below 1 °C, the solar pump is switched on when frost protection is activated. If the outdoor temperature rises above 1 °C again, the frost protection function is switched off.



Switching the frost protection function off or setting the minimum flow temperature too low can lead to severe damage to the system.

### System protection

#### Priority protection function

The system protection should prevent an overheating of the components installed in the system through the forced shut down of the solar circulation pump. If the value "AS Ton" on the collector has been exceeded for 1 Min. the pump will be turned off and not turn on again in order to protect the collector, for example, from steam. The pump will only be switched on again, when the collector temperature falls below "SP Toff".



With the system protection (on), there are increased standstill temperatures in the solar collector and therefore an increased pressure in the system. The operating manuals from the system components must be observed.

### Collector protection

#### Priority protection function

The collector protection prevents the collector from overheating. A forced switching of the pump makes sure that the collector is cooled through the storage. If the value "KS Ton" is exceeded on the collector, the pump will be turned on in order to cool the collector. The pump is shut down if the value "KS Toff" on the collector is not met or the value "KS Tmax Sp." on the storage is exceeded.



System protection has priority over collector protection! Even if the switch requirements for the collector protection are present, the solar circulation pump is turned off once "AS T on" is reached. Normally the values from the system protection (depending on the maximum temperature of the storage or other components) are higher than the collector protection.

### Collector alarm

If this temperature at the collector sensor is exceeded when the solar pump is turned on, a warning or error notification is triggered. There is a corresponding warning in the display.

## Recooling

In the system hydraulics with solar, excess energy is guided from the storage back to the collector with an activated return cooling function. This only occurs if the temperature in the storage is greater than the value "Return cooling Tref" and the collector is at least 20 °C colder than the storage and until the storage temperature has fallen below the value "Return cooling Tref". For multi-storage systems, the return cooling applies to all storage.

 Energy is lost through the collector through this function! The recooling should only be activated in cases of exception, with low heat acceptance, for example, during vacation.

## Anti-Legionella

 The anti-legionella function is an additional function for certain relay functions such as: electric heating rod, burner, circulation, compressor.

With the help of the anti legionella function (hereinafter referred to as: AL), the system can be heated up at selected times in order to free it of legionella.

 In the delivery state, the anti legionella function is switched off.

 Antilegionella function is not shown in the menu "Protective functions". It is instead shown as submenu of the corresponding special function. Special functions with AL include: Solar, burner, circulation and compressor.

 As soon as it has heated up with "AL" turned on, information with the date will be shown in the display.

 This anti legionella function does not offer any secure protection against legionella, because the controller requires an adequate added amount of energy and the temperatures cannot be monitored in the entire storage area and the connected pipe system.

 During the operation of the anti legionella function, if applicable, the storage is heated above the set value "Tmax", which may lead to scalding and system damage.

## 7. Special Functions

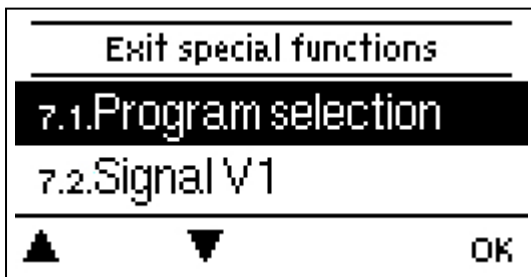

Used to set basic items and expanded functions.

 The settings in this menu should only be changed by a specialist.

## Program selection

Here the hydraulic variation fitting to the respective use case is selected and set.

 The program selection normally occurs only once during the first entry into service by a specialist. An incorrect program selection may lead to unpredictable errors.

## Signal

In this menu, the preset profiles for the signal can be selected or under "manual" all settings can be done personally. The settings can still be changed after a profile has been selected.

## Signal type

Only available, if the function is used on one of the V-outputs. The type of device to be controlled is set here.

**0-10V:** Controlled by a 0-10V signal.

**PWM:** Control by means of a PWM signal.

## Output Signal

In this menu the type of actors are set: heating pumps have the greatest output with a small input signal, solar pumps in contrast have very little output with a small input signal. Solar = normal, heating = inverted. For 0-10 V pump always choose the "Normal" setting

### PWM / 0-10V off

This voltage / this signal is emitted if the actor is turned off (actor with cable break detection require a minimum voltage / a minimum signal).

### PWM / 0-10V on

This voltage / signal is required the actuator to switch on and run at minimum speed.

### PWM / 0-10V max.

With this value, the maximum voltage level / maximum signal can be specified for the highest speed of the actuator, which is used, for example, during the purging or manual operation.

## Show signal

Represents the set signal in a graphic and text overview.

## **Speed control**

---

If the speed control is activated, it STDC offers the possibility through a special internal electronic system to change the speed of pumps depending on the process. The relay R1, R2 and the Pwm and 0-10V outputs can work with the speed controlled.



This function should only be activated by a technician. Depending on the pump being used and the pump level, the minimum speed may not be set too small, because the pump or the system may be damaged. The specifications from the affected manufacturer must be observed for this! When in doubt, the min. speed and the pump level should be set too high instead of too low.

## Variant

The following speed variants are available here:

**Off:** There is no speed regulation. The connected pump is only turned on or off with full speed.

**Mode M1:** The controller changes to the set max. speed after the purging time. If the temperature difference  $\Delta T$  between the reference sensors is below the set switch on temperature difference  $\Delta T R1$ , the speed will be reduced. If the temperature difference between the reference sensors is above the set switch on temperature difference  $\Delta T R1$ , the speed will be increased. If the controller has decreased the speed of the pump to the smallest level and the  $\Delta T$  between the reference sensors is still only  $\Delta T_{off}$ , the pump will be turned off.

**Mode M2:** The controller changes to the set min. speed after the Speed. If the temperature difference  $\Delta T$  between the reference sensors is above the set switch on temperature difference  $\Delta T R1$ , the speed will be increased. If the temperature difference  $\Delta T$  between the reference sensors is below the set switch on temperature difference  $\Delta T R1$ , the speed will be reduced. If the controller has decreased the speed of the pump to the smallest level and the  $\Delta T$  between the reference sensors is still only  $\Delta T_{off}$ , the pump will be turned off.

**Mode M3:** The controller changes to the set min. speed after the Speed. If the temperature on the reference sensors is above the set value to be set in the following, the speed will be increased. If the temperature on the reference sensors is below the set value to be set in the following, the speed will be reduced.

## Purging time

For this time, the pump runs with its full speed (100%) in order to guarantee a secure start-up. Only after expiration of this purging time will the pump have a controlled speed and will switch, depending on the set variant, to the max. or min. speed. Speed.

## Sweep time

With the control time, the inertia of the speed control is determined in order to prevent strong temperature deviations as much as possible. The timespan is entered here, which is needed for a complete cycle from minimum speed to maximum speed.

## Max. Speed

The maximum speed of the pump is determined here in %. During the setting, the pump runs in the respective speed and the flow can be determined.



The specified percentages are variables, which may deviate more or less strongly depending on the system, pump and pump

level. 100% is the maximum possible power of the controller.

## Min. Speed

The minimum speed of the pump is determined here. During the setting, the pump runs in the respective speed and the flow can be determined.

 The specified percentages are variables, which may deviate more or less strongly depending on the system, pump and pump level. 100% is the maximum possible power of the controller.

## Setpoint

This value is the control setpoint for mode 3 "Variant" on page 20, only version 2.3, and 4.. If this value is below at the sensor, the speed is reduced. When it is exceeded, the speed is increased.

## Time & Date

Serve to set the current time and date.

 For time-dependent functions such as circulation and anti-legionella and the evaluation of system data, it is essential that the time is accurately set on the controller. Please note that the clock continues to run for about 24 hours if the mains voltage is interrupted, and afterward must be reset. Improper operation or an incorrect time may result in data being cleared, recorded incorrectly or overwritten. The manufacturer accepts no liability for the recorded data!

## Sensor Calibration

Deviations in the temperature values displayed, for example. due to cables which are too long or sensors which are not positioned optimally can be compensated for manually here. The settings can be made for each individual sensor in steps of 0.5 °C.

 Settings are only necessary in special cases at the time of initial commissioning by the specialist. Incorrect measurement values can lead to unpredictable errors.

## Commissioning

Starting commissioning help guides you in the correct order through the basic settings necessary for commissioning, and provides brief descriptions of each parameter in the display. Pressing the ,esc' key takes you back to the previous value so you can look at the selected setting again or adjust it if desired. Pressing ,esc' more than once takes you back to the selection mode, thus cancelling the commissioning help ("Commissioning help" on page 14).

 May only be started by a specialist during commissioning! Observe the explanations for the individual parameters in these instructions, and check whether further settings are necessary for your application.

## Factory settings

All settings can be reset, returning the controller to its delivery state.

 All of the controller's parametrization, statistics, etc. will be lost irrevocably. The controller must then be commissioned once again.

## Heat quantity

### Constant flow

If "Constant flow" is activated as the type of heat quantity metering, the approximate heat from the manually entered values for antifreeze, its concentration and the flow from the system and the measured sensor values from the collector and storage are calculated. Additional information about antifreeze, its concentration and the flow of the system is required. Additionally through the setting offset  $\Delta T$ , a correction factor can be set for the heat quantity collection. Since the collector temperature and the storage temperature can be used for the heat quantity metering, depending on the system, there may be deviations from the displayed collected temperature to the actual previous temperature or the displayed storage temperature to the actual return temperature. Through the setting Offset  $\Delta T$ , this deviation can be corrected.

Example: displayed collector temperature 40°C, read previous temperature 39°C, displayed storage temperature 30°C, read return temperature 31° means a setting of -20% (displayed  $\Delta T$  10K, actual  $\Delta T$  8K => -20% correction value)

 The heat quantity data in the "Constant flow" mode only consists of calculated values for the functional inspection of the system.

## Starting aid

For some solar systems, in particular for vacuum tube collectors, the measurement recording on the collector sensors may be too slow or imprecise, because the sensor is often not on the warmest spot. With an activated starting aid, the following procedure occurs: If the temperature on the collector sensor increases within a minute by the value defined under "increase", the solar circulation pump will be turned on for the set "purging time" so that the medium to be measured is transported to the collector sensor. If there is still no normal switching condition through this, there will be a 5 minute block time for the start wizard function.

 This function should only be activated by a technician if problems occur with the measurement recording. Observe in particular the instructions from the collector manufacturer.

The menus "Purging time" and "Increase" are only displayed when the starting aid function is set to "On".

### Purging time

If the temperature on the collector sensor increases within a minute by the value defined under "increase", the solar circulation pump will be turned on for the set "purging time" so that the medium to be measured is transported to the collector sensor. If the set  $\Delta T$  is not reached, a 5-minute circulation pause time for the starting aid function will apply.

### Increase

If the temperature at the collector reaches within a minute the value defined, the solar pump is turned on for the duration of the purging time.

## Daylight saving time

If this function is activated, the controller automatically changes to winter time or summer time (DST, Daylight Savings Time).

## 8. Menu Lock



Secure the controller against unintentional changing and compromise of basic functions.

Menu lock active = "On"

Menu lock off = "Off"

In addition, the "Simple" menu view can be used to hide menu items that are not necessary for the daily use of the controller after commissioning. The menu item "Menu lock on/off" is also hidden when the "Simple" menu view is selected!

The menus listed below remain completely accessible despite the menu lock being activated, and can be used to make adjustments if necessary:

1. Measurement values
2. Statistics
4. Settings
6. Special Functions
7. Menu lock
9. Language

## 9. Service Values

9.1.	STDC-V3
9.2.	2015/06/11.15 175
9.3. Tmin S1	20°C

Serve for remote diagnosis by a specialist or the manufacturer in the event of errors, etc.

 Enter the values into the table when an error occurs.

## 10. Language



To select the menu language. During initial commissioning and longer power interruptions, the query is made automatically. The choice of languages may differ depending on the model. Language selection is not available for every model.

## Malfunctions/Maintenance

### Replacing the Fuse

 Repairs and maintenance may only be performed by a specialist. Before working on the unit, switch off the power supply and secure it against being switched on again! Check that there is no power flowing!

 Only use the supplied spare fuse or a fuse of the same design with the following specifications: 2 AT/250 V.

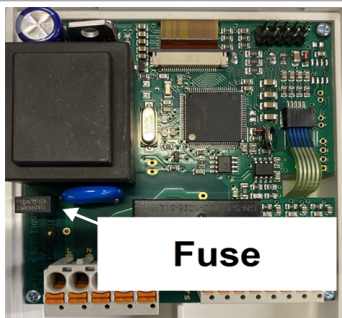

If the mains voltage is switched on and the controller still does not function or display anything, then the internal device fuse may be defective. First find the external fault source (e.g. pump), replace it and then check the device fuse.

To replace the device fuse, open the device as described under " wall Installation " on page 11", remove the old fuse, check it and replace if necessary.

Then first recommission the controller and check the function of the switch outputs in manual mode as described in Section 3.2..

### Maintenance

 In the course of the general annual maintenance of your heating system, the functions of the controller should also be checked by a specialist and the settings should be optimized if necessary.

### Performing maintenance:

- Check the date and time " Time & Date " on page 21
- Assess/check plausibility of statistics " Statistics " on page 15
- Check the error memory " Message Log " on page 15
- Verify/check plausibility of the current measurement values " Measurement values " on page 14
- Check the switch outputs/consumers in manual mode " Manual " on page 16
- Possible optimization of the parameters setting (**only on customers request**)

### Possible error messages

Possible error messages	Notes for the specialist
Sensor x defective	Means that either the sensor, sensor entrance on the controller or the connecting wire was defective (" Temperature Resistance Table for Pt1000 Sensors " on page 13).
Collector alarm	Means that the temperature on the collector set under "Collector protection" was exceeded.
Restart	Means that the controller was restarted, for example, due to a power outage. Check date & time!
Time & Date	This display appears automatically after a longer network disruption, because the time & date must be examined and, if applicable, adjusted.

Final Declaration

Although these instructions have been created with the greatest possible care, the possibility of incorrect or incomplete information cannot be excluded. Subject as a basic principle to errors and technical changes.

**Date and time of installation:**

**Name of installation company:**

**Space for notes:**

Your specialist dealer:

Manufacturer:

SOREL GmbH Mikroelektronik  
Reme-Str. 12  
D - 58300 Wetter (Ruhr)

+49 (0)2335 682 77 0  
+49 (0)2335 682 77 10

info@sorel.de  
www.sorel.de

Version: 02.07.2024  
SOREL